

Description

Titan 340L Split Heat Pump

Model

340-17ASW-134

Dimensions

2110 x 650mm

660 x 635mm

Evaporator may be remotely installed up to 7m from the tank.

Hot Water Production

Rate L/hr (COP)

131 (3.57)

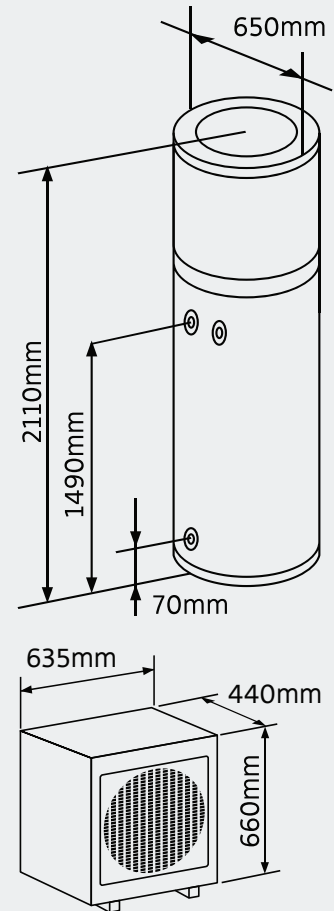

Specifications

Storage Size	340 L
Rated Delivery	315 L
Heating Output	6.22 kW
Power Input	1.66 kW
COP of Heating*	3.57 @20°C
Water Temp Setting	60°C
Maximum Tank Temp Setting	70°C
Compressor	39cc Rotary
Refrigerant	R134a
Electrical Supply	220-240V/50Hz/1Ph
Circuit	15 Amps

Water Connections	3/4" BSP - 20mm
PTR Valve Setting	850 kPa
Expansion Ctrl Valve (ECV) Setting	700 kPa
PLV (without ECV fitted / with ECV fitted)	500 kPa / 350 - 500 kPa
Operating Sound Level**	58 dBA
Nett (Empty) Weight	165 kg (tank) 35kg (module)
Ambient Operating Temperature	-10 °C to +40 °C
Warranty	5 years (5 years tank, 2 years electric and refrigeration)*

Make your next water heater a Quantum heat pump.

For more information call 1800 644 705 or visit quantumenergy.com.au

*Refer to quantumenergy.com.au for warranty details or call 1800 644 705 | Under its policy of ongoing product development, Quantum Energy may from time to time change product specification without notice. All dimensions given are approximate and should be checked prior to installation.



Hot water production rate

Ambient Temperature	Hot Water Production Rate (COP)
35°C	199LPH (5.30)
30°C	177LPH (4.69)
25°C	154LPH (4.09)
20°C	131LPH (3.57)
15°C	109LPH (3.03)
10°C	90LPH (3.03)
5°C	73LPH (2.53)
0°C	59LPH (1.71)
-5°C	51LPH (1.50)
-10°C	45LPH (1.34)

Applications

Suitable for hotels, motels and resorts, apartment complexes, recreational facilities, agriculture and industrial applications. Installable in a manifold configuration for centralised/loop systems.

The Titan Compact Split Unit is designed to be installed internally (for example a plant room) whereby the airbox can be located externally up to 7 metres away.

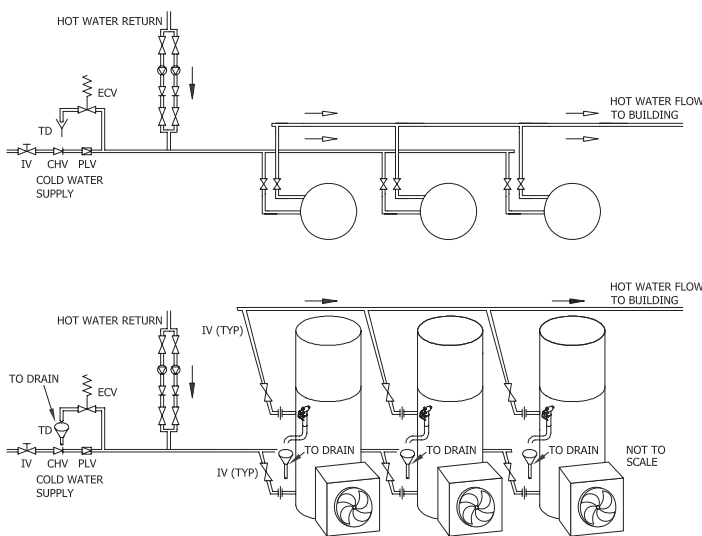

Government Rebates Available

Federal Government Grants Small-Scale Technology Certificate (STCs)

Quantum heat pumps systems are eligible for grants through the Federal Governments Small-scale Renewable Energy Scheme. These grants are called Small-scale Technology Certificates (STCs) and are offered based on how sustainable a hot water system is. Your STC rebate value will depend on your installation location and size of system selected.

Please visit www.rec-registry.gov.au/rec-registry/app/calculators/swh-stc-calculator to calculate your STCs.

State Grants

Victoria

For Victorian consumers there are additional rebates available for replacing inefficient hot water systems with Heat Pumps. Victorian Energy Efficiency Certificates (VEECs) are offered for eligible installations on top of the Federal STC grants. There are several activities which create VEECs as follows:

- Activity 1D Is for replacing an electric storage hot water system with an energy efficient heat pump in a residential setting.
- Activity 44A Replacing a gas hot water system with a heat pump in a business or commercial setting.
- Activity 44B Replacing an electric hot water system with a heat pump in a business or commercial setting.
- Activity 44C Installing a new heat pump hot water system in a business or commercial setting.

For more information please visit:

www.veu-registry.vic.gov.au/Public/Public.aspx

NSW

For New South Wales consumers there are additional rebates available for replacing inefficient hot water systems with Heat Pumps. Energy Savings Certificates (ESCs) are offered for eligible installations on top of the Federal STC grants. There are several activities which create ESC's as follows:

- IHEAB Replacing an existing commercial gas or electric hot water system with a new energy efficient heat pump. Only applies to commercial buildings.
- HEER Replacing an existing electric or gas storage hot water system with an energy efficient heat pump system at a residential property.

For more information please visit:

www.energysustainabilityschemes.nsw.gov.au/Home/About-ESS/Overview-of-the-ESS

Make your next water heater a Quantum heat pump.

For more information call 1800 644 705 or visit quantumenergy.com.au

*Refer to quantumenergy.com.au for warranty details or call 1800 644 705 | Under its policy of ongoing product development, Quantum Energy may from time to time change product specification without notice. All dimensions given are approximate and should be checked prior to installation.



AS2712 LIC_2650
SAI GLOBAL

AS3498 WMKA2531
SAI GLOBAL